

LC0603 Ceramic Core

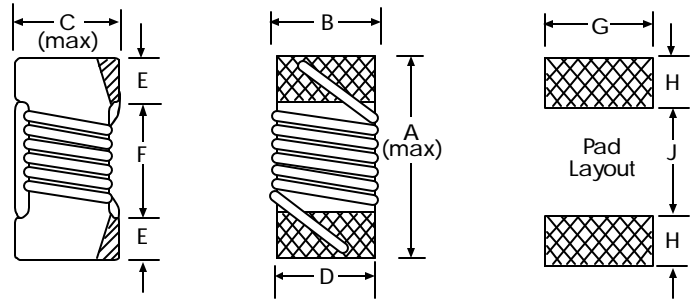
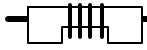

APPLICATIONS

- LC resonant circuits such as oscillators and signal generators
- Impedance matching
- Circuit isolation
- RF filters
- Disk drives and computer peripherals
- Audio equipment
- Video equipment
- TV and radio
- Telecommunication equipment

CHARACTERISTICS

DIELECTRIC STRENGTH: 500 Volts RMS at sea level.
OPERATING TEMPERATURE: -25°C to +85°C.
STORAGE TEMPERATURE: -45°C to +100°C in original tape and reel package.
SOLDERING HEAT RESISTANCE: 250°C for 10 seconds after 120°C preheat cycle for 5 minutes.
SOLDERABILITY : Terminals are covered 95% with solder
RESISTANCE TO SOLVENT: No change in appearance when dipped into alcohol or freon for 3 minutes.
MARKING: Marked with inductance value in EIA code.

Notes:

- (1) Available tolerances: (G) 2%, (J) 5%, (K) 10%, (M) 20%.
- (2) Q measured using HP4286ARF Impedance Analyzer with HP16193A Test Fixture.
- (3) R_{dc} measured using HP4286A.
- (4) SRF measured using HP8753D Network Analyzer.
- (5) Packaging: Tape and Reel only.

A MAX.	B MAX.	C MAX.	D	E	F	G	H	J
1.57	1.02	0.92	0.76	0.33	0.86	1.02	0.64	0.64
0.062	0.040	0.036	0.030	0.013	0.034	0.040	0.025	0.025

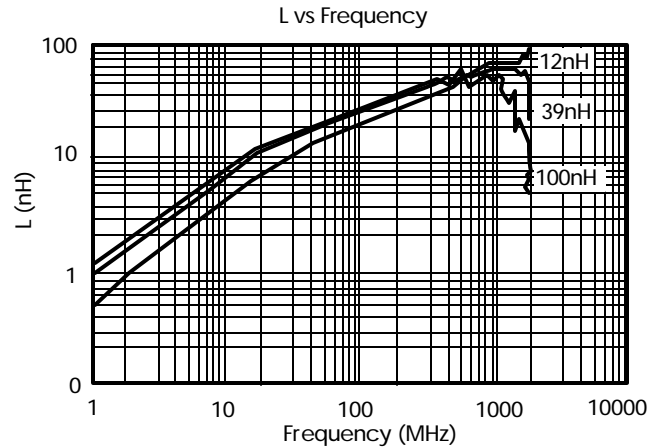

PART NUMBER (1)	INDUCTANCE (nH)	Q MINIMUM (2)	TEST FREQUENCY (MHz)	DC RESISTANCE OHMS MAX (W) (3)	RATED DC CURRENT MAX (mA)	SELF RESONANT FREQUENCY (MHz) (4)
LC0603-1N8	1.8	4	250	.07	700	8000
LC0603-3N9	3.9	9	250	.07	700	7240
LC0603-6N8	6.8	30	250	.08	700	6938
LC0603-8N2	8.2	30	250	.09	700	6836
LC0603-100	10	28	250	.09	700	6636
LC0603-120	12	21	250	.12	700	5091
LC0603-150	15	22	250	.25	700	4752
LC0603-180	18	24	250	.25	700	3659
LC0603-220	22	27	250	.15	700	3267
LC0603-270	27	35	250	.16	600	2959
LC0603-330	33	33	250	.23	600	2652
LC0603-390	39	32	250	.27	600	2454
LC0603-470	47	34	200	.49	600	2321
LC0603-560	56	33	200	.35	600	2228
LC0603-680	68	37	200	.39	600	2002
LC0603-720	72	35	150	.53	400	1844
LC0603-820	82	39	150	.58	400	1851
LC0603-101	100	36	150	.80	400	1625
LC0603-111	110	45	150	.86	300	1505
LC0603-121	120	48	150	.92	300	1451